CLEMENTS

proven through performance

Low Vacuum Low Flow Regulator SUC 89150 SUC 89152



User Manual

Manual No. SUC 91005 428
Issue 8

Safety

Thank you for purchasing this Clements Low Vacuum Low Flow Regulator.

For your safety it is imperative that this unit only be operated by authorised personnel in accordance with the instructions as described in this manual. Operated in this way, the Low Vacuum Low Flow Regulator will provide years of service.

Due to continual improvements in product design, the Low Vacuum Low Flow Regulator may vary in detail from the descriptions in this manual. In the event of further questions please contact your local distributor or BMDi TUTA Healthcare direct.

User Manual
Low Vacuum Low Flow Regulator
Manual Number SUC 91005 428 Issue 8

Copyright © 2010 BMDi TUTA Healthcare Pty Ltd

The information in this manual was originated by, and is the exclusive property of BMDi TUTA Healthcare Pty Ltd. It is furnished for customer information only, and is not an authorisation or licence to make this product or to furnish this information to others.



BMDi TUTA Healthcare Pty Ltd
Level 17, 275 Alfred St
North Sydney NSW 2060
Australia
Phone: +61 2 9466 5300
Fax: +61 2 9922 7165
Website: www.medaust.com



Priority Analysts Ltd
The Pinnacle, 160 Midsummer Boulevard,
Milton Keynes, MK9 1FF, United Kingdom



Contents

Specifications	4
Transportation and Storage	5
Installation	6
Operation	7
Safety Test	8
Maintenance	9
Cleaning and Sterilisation	10
Spare Parts	10
Disassembly and Reassembly	12
Parts Assembly	16
Troubleshooting	17
Warranty	18

Intended Use

To vary the vacuum level of a continuous vacuum source, within the stated operating vacuum range, for the aspiration of fluids and particulate matter in medical procedures carried out by clinically trained and authorised personnel.

Specifications

Vacuum Range	0 to –150 mmHg, 0 to –20 kPa
Maximum Flow	7 to 8 litres/minute
Flow Rate	0 to 8 litres of Free Air Per Minute (LFAPM)
Regulator Mechanism	Suspended frictionless double diaphragm
Filter	Porous bronze filter, 90 micron
Safety	Pressure safety valve, ball and seat type
Gauge	Diaphragm type; Dual scale, graduated in kPa and mm Hg
Gauge Range	0 to –25 kPa, graduated at 1.0 kPa 0 to –200 mmHg, graduated at 5 mmHg
Duty Cycle	Continuous operation
Dimensions	278H x 65W x 132D
Weight	1.0kg
Ambient Temperature	+5°C to 35°C
Standard Conditions	25°C, Sea Level, 101kPa
GMDN Code	37780
ARTG Number	174684
Class	Class I (EU Class IIa)

Transportation and Storage

Environmental conditions for transportation and storage are shown in the following table.

Parameter	Minimum	Maximum
Temperature	10°C	40°C
Humidity	60% RH	95% RH
Barometric Pressure	700 mBar	1060 mBar

Warning Symbols Legend

The warning symbols marked on the equipment and their meanings are shown as follows.



Caution, consult accompanying documents

Waste Materials

The contents of the collection jars, suction tubing, bacteria filter, internal exhaust filter may contain biohazard wastes. Handle using safe handling procedures, which may include the use of rubber gloves and eye protection, and dispose of according to local protocols for biohazard materials.

Recycling

At the end of their service life, the Controller should be dismantled if necessary, and returned to a local materials recycling centre.

Installation

Carefully examine the suction regulator for any visual signs of damage that might have occurred during shipment.

Screw the suction regulator to the wall outlet with the index handwheel or slot “V” at back of body into mounting wall bracket located at the back of the unit.

Turn on full vacuum by rotating the control knob fully clockwise. Occlude the regulator exhaust and check that the safety valve is operating. The valve should operate at 150 mm Hg (-20 kPa).

If the above reading is not obtained, the safety valve is not working correctly.

To rectify the problem carry out the following

- 1 Disconnect regulator from vacuum supply.
- 2 Remove the safety jar and unscrew the safety valve assembly. Do not block the Safety Valve hole as this will cause damage to the gauge if the vacuum is not disconnected.
- 3 Thoroughly clean all components.
- 4 Connect to a vacuum supply and turn the control knob to the fully on position.
- 5 Reassemble the safety valve components, apply a small amount of ‘Loctite’ to the thread and screw the assembly into the jar cap approximately three turns.
- 6 Fit the safety jar, occlude the suction inlet and check gauge reading.
- 7 If any further adjustment is required, remove the safety jar and screw the safety valve in or out to obtain the correct reading.

N.B. Do not block Safety Valve as this will cause damage to the Gauge which will not be covered by the warranty.

Operation

To set the regulator to desired setting

- 1 Occlude inlet
- 2 Wind regulator control knob to register higher than required setting
- 3 Allow setting to stabilise
- 4 Slowly wind back regulator knob to required level
- 5 Release inlet
- 6 Occlude inlet and check the unit returns to set level
- 7 Release inlet and apply to patient

Safety Test for Vacuum Regulator with Variable Setting

- Install the regulator to be tested as shown in the diagram.
- Set the vacuum source to -79 kPa and the regulator to -20 kPa or one fifth of full scale.
- Reduce the vacuum source to -53 kPa and read the new occluded vacuum on the regulator gauge.
- Set the regulator to -53 kPa or four fifths of full scale and adjust the vacuum source from -53 kPa to -79 kPa.
- Read the new occluded vacuum on the regulator gauge.
- Adjust the vacuum source from -79 kPa to -53 kPa and read the new occluded vacuum on the regulator gauge.
- Repeat the above three times.

Each time the source vacuum is changed the regulator gauge should read within 0.4 kPa of its' setting before the change.

Arrangement For Testing Vacuum Regulator Setting

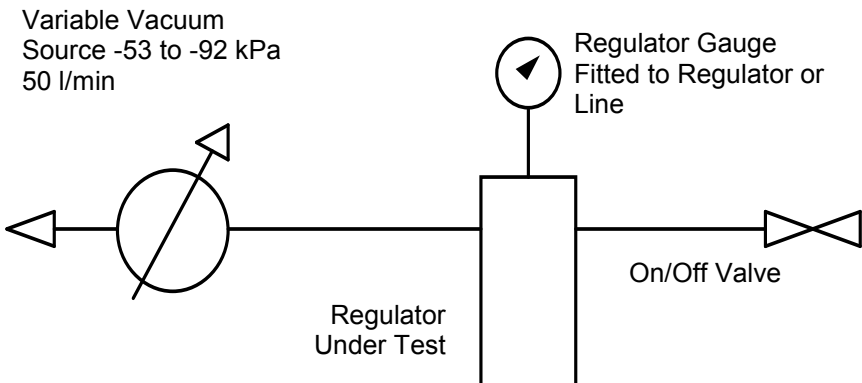

Maintenance

Year	1st Quarter	2nd Quarter	3rd Quarter	4th Quarter
1	Check flow, vacuum, bronze filter and safety valve	Check flow, vacuum, bronze filter and safety valve	Check flow, vacuum, bronze filter and safety valve	Check flow, vacuum, bronze filter and safety valve
2	Check flow, vacuum, bronze filter and safety valve	Check flow, vacuum, bronze filter and safety valve	Check flow, vacuum, bronze filter and safety valve	Check flow and vacuum. Strip and inspect safety valve parts and replace 'O' ring and filter.
3	Check flow, vacuum, bronze filter and safety valve	Check flow, vacuum, bronze filter and safety valve	Check flow, vacuum, bronze filter and safety valve	Check flow, vacuum and safety valve. Check filter and seals, replace if necessary.
4	Check flow, vacuum, bronze filter and safety valve	Check flow, vacuum, bronze filter and safety valve	Check flow, vacuum, bronze filter and safety valve	Check flow and vacuum. Strip and inspect safety valve parts and replace 'O' ring
5	Check flow, vacuum, bronze filter and safety valve	Check flow, vacuum, bronze filter and safety valve	Check flow, vacuum, bronze filter and safety valve	Check flow, vacuum and safety valve. Check filter and seals, replace if necessary.

Cleaning and Sterilisation : Regulator

Warning

Do not immerse or autoclave the Regulator unless the gauge, diaphragm assembly and nylon balls have been removed.

Cleaning

Clean using a pH neutral disinfectant for wiping or immersion cleaning. Flush after immersing using distilled water and dry thoroughly before reassembly of the Regulator.

Sterilisation

The Regulator may be safely autoclaved at 121°C for 15 minutes, once the gauge, diaphragm assembly and nylon balls have been removed.

Cleaning and Sterilisation : Jar

Cleaning

Clean using a pH neutral disinfectant for wiping or immersion cleaning. Flush after immersing using distilled water and dry thoroughly before reassembly of the Jar.

Sterilisation

The MAK collection jar and components are all autoclavable. The jar and components may be safely autoclaved at 121°C for 15 minutes.

Spare Parts

SUC 80253	Low Vacuum Gauge
SUC 80297 001	KIT Yellow medical suction tubing (20 metre roll)
SUC 81500 043	Vacuum Controller spring
SUC 89104	KIT connector Drager
SUC 89101	KIT connector BS MK IV
SUC 89102	KIT connector Puritan Bennett
SUC 89140 029	Knob Tension Spring
SUC 89140 036	KIT Overhaul for Regulators ('O' Ring x4, Large Diaphragm, Small Diaphragm, Valve Seat)
SUC 89140 085	MAK 300 antibacterial canister and lid
SUC 89140 087	Adapter for attaching canister to regulators
SUC 89150 011	Regulator Assembly Handle Tool
SUC 89150 012	Regulator Assembly Tool
SUC 89210	Assembled Safety Trap Jar for Regulators
SUC 89240 081	MAK 500 canister with lid
SUC 89240 084	MAK 500 jar only
SUC 89240 088	MAK 300 jar only
SUC 89240 090	HEPA bacterial filters for MAK 300 (Pack of 20)
SUC 89250 024	KIT for Regulators
SUC 89310 001	Porous Bronze Filter (Pack of 20)
SUC 89455 001	KIT Plastic V bracket to hold suction devices (Pack of 5)
SUC 91005 428	User Manual for the Low Vacuum Low Flow Regulators SUC89150 / SUC89152

Disassembly and Reassembly

The Clements Suction Regulator is a precision machined and assembled device that will, under normal operation, provide many years of service. In the event of any malfunction that requires the unit to be dismantled the procedures described below should be followed.

Tools Required

Adjustable Wrench

Allen Keys

Circlip Pliers (internal)

Small Screwdriver

Drill Press (or G Clamp)

Special Tools (Clements SUC 89150 011 and SUC 89150 012)

Disassembly

1. Remove vacuum gauge.
2. Remove safety jar and bronze filter.
3. Remove safety jar cap by unscrewing the securing screw. Take care that the small 'O' ring seal is not lost.
4. Remove the control knob by loosening the two grub screws.
5. Remove the compression spring and two nylon washers.
6. Remove the stop screw from the main body.
7. Remove the circlip that retains the piston assembly and the belleville washer.
8. Remove the piston assembly.
9. Unscrew the diaphragm compressor (left hand thread).
10. Remove the circlip from the spring barrel and take out the control screw and spring.
11. Remove the adjusting set screw and spring from inside the control screw.
12. Remove the diaphragm and valve assembly.
13. Remove the countersunk head screw and disassemble the diaphragm and valve assembly.

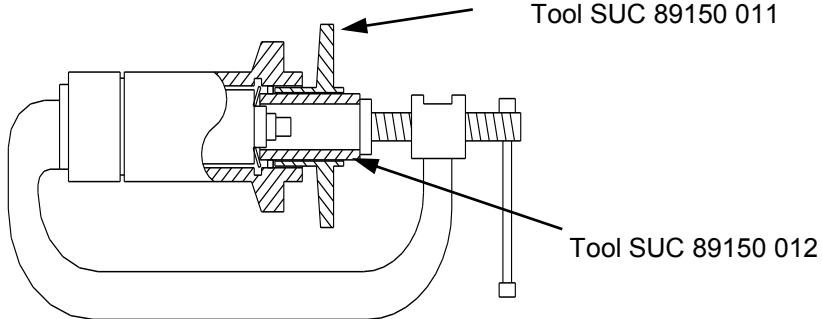

Reassembly

- 1 Reassemble the diaphragm and valve assembly and replace the countersunk head screw.
- 2 Lightly grease the fibre washer and reassemble the adjusting set screw and spring into the control screw.
- 3 Insert the control screw and spring into the spring barrel and secure with the circlip.
- 4 Replace the diaphragm compressor (left hand thread) so that it rests lightly against the diaphragm assembly.
- 5 Replace the belleville washer.
- 6 Compress the belleville washer and replace the large circlip. (Clements special tools SUC 89150 011 and SUC 89150 012 will be needed for this operation).
- 7 Refit the stop screw into the main body.
- 8 Refit the vacuum gauge using a suitable thread sealant.
- 9 Place the nylon and fibre washers and knob spring into position.
- 10 Lightly grease the 'O' ring and refit the jar cap to the main body with the securing screw.

- 11 Place the bronze filter in its position with a twisting action.
- 12 Insert the safety jar into the jar cap.
- 13 Connect the regulator to a vacuum supply.
- 14 Occlude the inlet hole at the bottom of the main body and slowly adjust the control screw until the vacuum gauge just lifts off the zero position. This must be done in conjunction with setting the Safety Valve. The adjusting control screw must be wound up in 0.2 kPa steps as should also the Safety valve until the reading of 20 kPa is reached. When first occluding the inlet take care that the gauge does not over run the end of its scale.
- 15 Carefully push the control knob onto the control screw and lock it into position with the socket head screw. Ensure that the stop pin is hard against the left hand side of the stop screw.
- 16 Ensure that the vacuum gauge still lifts slightly off the zero position with the knob in the off position and the inlet occluded.
- 17 Remove the control knob label
- 18 Using a small screwdriver through the hole in the control knob and with the control knob in the off position, turn the adjusting set screw until the vacuum gauge reads zero. This should be done whilst regulator is connected to a 0 – 12 lpm flowmeter to assist in checking for vacuum leakage.
- 19 Ensure that the grub screws in the knob are tight and replace the label.
- 20 Test the regulator as described in the Installation and Operation section.

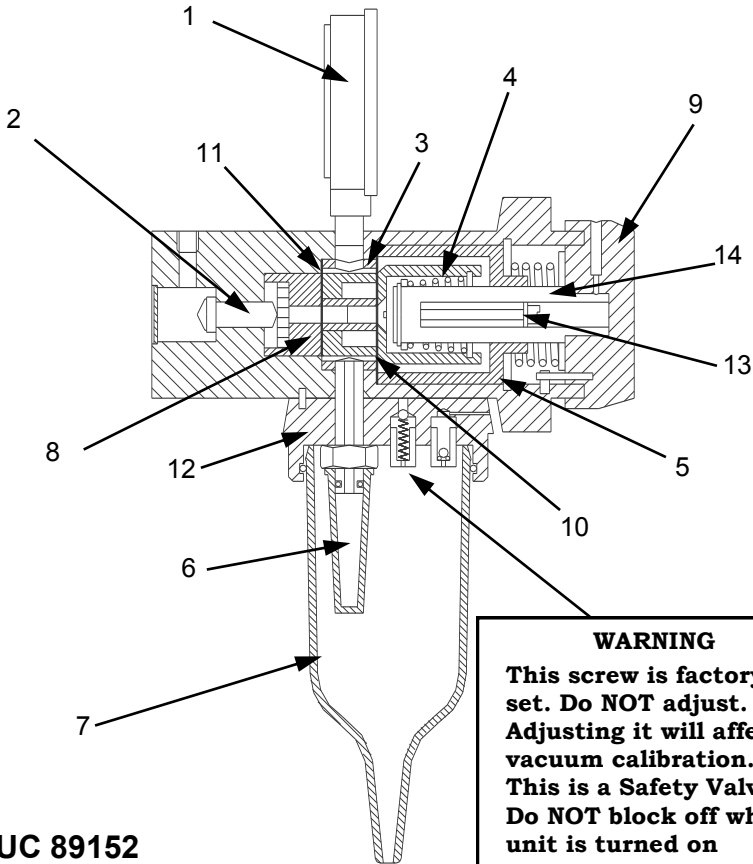

SUC 89152

Item	Description	Item	Description
1	Gauge	8	Piston Assembly
2	Valve	9	Control Knob
3	Outer Spacer	10	Large Diaphragm
4	Control Spring	11	Small Diaphragm
5	Diaphragm Compressor	12	Jar Cap
6	Bronze Filter	13	Adjusting Screw
7	Safety Jar	14	Control Screw

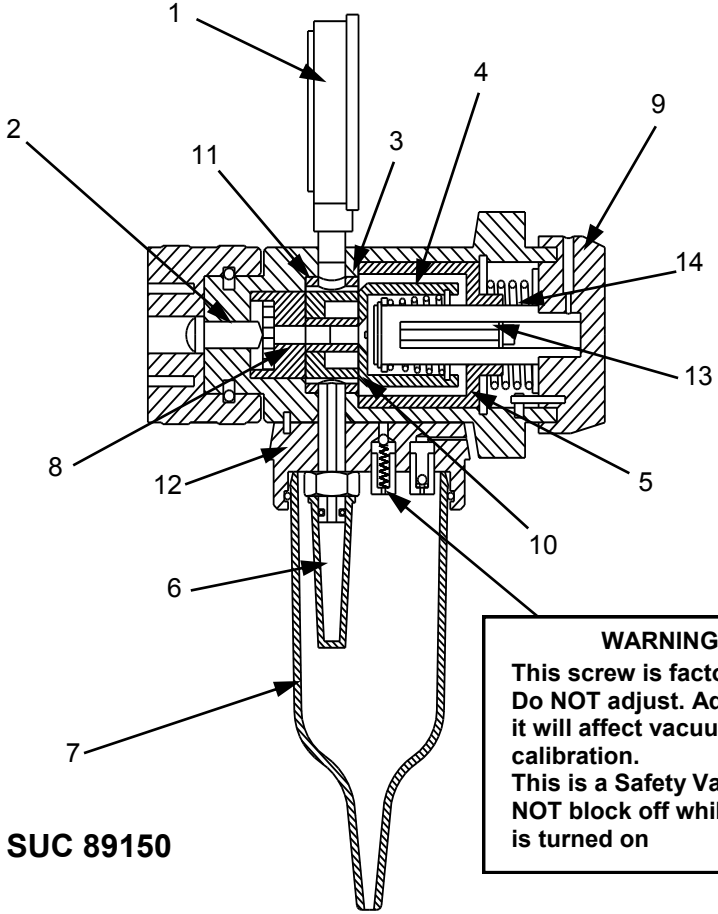

WARNING
 This screw is factory set.
 Do NOT adjust. Adjusting
 it will affect vacuum
 calibration.
 This is a Safety Valve. Do
 NOT block off while unit
 is turned on

SUC 89150

Item	Description	Item	Description
1	Gauge	8	Piston Assembly
2	Valve	9	Control Knob
3	Outer Spacer	10	Large Diaphragm
4	Control Spring	11	Small Diaphragm
5	Diaphragm Compressor	12	Jar Cap
6	Bronze Filter	13	Adjusting Screw
7	Safety Jar	14	Control Screw

Troubleshooting

Fault	Check	Rectify
No reading on suction gauge	Pipeline supply Safety Jar fitting 'O' Ring Seal Connection to wall Blockage in regulator	Supply source Tighten into body Replace if damaged Tighten handwheel Dismantle and clean
Full scale reading on suction gauge at all settings	Debris on valve seat	Dismantle and clean
Suction gauge reading	Debris on valve seat	Dismantle and clean
Suction gauge reading creeps downwards	Pipeline supply Safety Jar fitting 'O' Ring Seal Regulator Diaphragms	Supply source Tighten into body Replace if damaged Dismantle and check replace if damaged
Slow response to suction setting	Bronze Filter Metering Jet	Clean or replace Replace if worn

Warranty

BMDi TUTA Healthcare Pty Limited ("BMDi TUTA Healthcare") warrants that this product is free from defects in workmanship and materials for a period of 12 months from the date of shipment by BMDi TUTA Healthcare or its authorised agent to the purchaser. Subject to the conditions of this warranty, if the product fails to operate for any reason within the warranty period and the product is returned to the place of purchase at the purchaser's expense, BMDi TUTA Healthcare will repair or replace the product free of charge.

If a valid warranty claim is made within 30 days from the date of shipment, then BMDi TUTA Healthcare will also reimburse the purchaser for reasonable freight costs in returning the product to the place of purchase.

Conditions of Warranty

1. The product must be returned to the place of purchase with proof of purchase.
2. This warranty is only available to the original purchaser of the product.
3. The product must not have had its serial number removed, defaced or changed, its casing opened, its power supply altered or have been tampered with in any other way.
4. This warranty does not cover :
 - inadequate or incorrect site preparation;
 - improper installation;
 - connection to the wrong voltage;
 - failure of the product due to misuse;
 - the use or operation of the product outside of the physical, electrical or environmental specifications of the product;
 - use in a manner or environment in which the product is not designed to be used;
 - improper adjustment, calibration or operation by the purchaser;
 - the use of accessories including consumables, hardware or software which were not manufactured or approved in writing by BMDi TUTA Healthcare;

- any modifications of the product which were not authorised in writing by BMDi TUTA Healthcare;
 - any contamination or leakages caused or induced by the purchaser; and
 - inadequate or improper maintenance of the product.
5. This warranty does not cover normal wear and tear.
 6. BMDi TUTA Healthcare will not be responsible for damage or loss caused during shipping.
 7. In Australia, apart from any warranties implied by the Trade Practices Act 1974 all other warranties expressed or implied and whether arising by virtue of statute or otherwise are hereby excluded.
 8. Outside Australia, all other warranties expressed or implied and whether arising by virtue of statute or otherwise (including any warranties implied by the Vienna Convention) are hereby excluded.
 9. BMDi TUTA Healthcare' obligations under this warranty are limited to the repair or replacement of the product, within the terms of this warranty and the total liability of BMDi TUTA Healthcare for loss or damage of every kind whether arising pursuant to the terms of the sale of the product or otherwise in connection with the product is limited to the amount paid by the purchaser to BMDi TUTA Healthcare for the product.
 10. Apart from any liability imposed by Part VA of the Trade Practices Act, BMDi TUTA Healthcare accepts no other liability for any loss or damage occasioned (including consequential loss or damages) in any way as a result of the use of the product.
 11. The warranty does not extend to cover damage to the following parts as they are inherently prone to wear :
 - motor brushes
 12. This warranty does not extend to cover corrosion due to any cause nor to any damage to painted or anodised surfaces.
 13. BMDi TUTA Healthcare will give the purchaser the benefit of any manufacturer's warranty in respect of any components in the product which were not manufactured by BMDi TUTA Healthcare, if such a manufacturer's warranty is available.

