

---

# **CLEMENTS**

---

proven through performance

## **SUC 89346 SUC 89347 High Vacuum High Flow Venturi Nozzle**



### **User Manual**

Manual No. SUC 91005 417  
Issue 5

---

## **Safety**

Thank you for purchasing this Clements High Vacuum High Flow Venturi Nozzle.

For your safety it is imperative that this unit only be operated by authorised personnel in accordance with the instructions as described in this manual. Operated in this way, the High Vacuum High Flow Venturi Nozzle will provide years of service.

Due to continual improvements in product design, the High Vacuum High Flow Venturi Nozzle may vary in detail from the descriptions in this manual. In the event of further questions please contact your local distributor or BMDi TUTA Healthcare direct.

User Manual

High Vacuum High Flow Venturi Nozzle

Manual Number SUC 91005 417 Issue 5

Copyright © 2010 BMDi TUTA Healthcare Pty Ltd

The information in this manual was originated by, and is the exclusive property of BMDi TUTA Healthcare Pty Ltd. It is furnished for customer information only, and is not an authorisation or licence to make this product or to furnish this information to others.



**BMDi TUTA Healthcare Pty Ltd**

**Level 17, 275 Alfred St**

**North Sydney NSW 2060**

**Australia**

**Phone: +61 2 9466 5300**

**Fax: +61 2 9922 7165**

**Website: [www.bmdituta.com](http://www.bmdituta.com)**

## **Contents**

<b>Specification.....</b>	<b>4</b>
<b>Installation and Operation.....</b>	<b>5</b>
<b>Vacuum and Flow Test .....</b>	<b>6</b>
<b>Anti-Blow Back Test .....</b>	<b>7</b>
<b>Accessories and Spares .....</b>	<b>8</b>
<b>Maintenance .....</b>	<b>9</b>
<b>Cleaning and Sterilisation.....</b>	<b>10</b>
<b>Troubleshooting .....</b>	<b>11</b>
<b>Disassembly and Repair .....</b>	<b>12</b>
<b>Warranty.....</b>	<b>14</b>

## Intended Use

To connect suction equipment to a continuous vacuum source terminal unit, for the aspiration of fluids and particulate matter in medical procedures carried out by clinically trained and authorised personnel.

## Specifications

<b>Vacuum Range</b>	0 to -100 kPa, [0 to -750 mmHg] (Subject to available wall suction)	
<b>Flow Rate</b>	0 to 35 Litres of Free Air Per Minute	
<b>Gauge (where fitted)</b>	Bourdon Tube type Dual scale, graduated in kPa and mmHg	
<b>Gauge Range</b>	0 to -100 kPa, graduated at 5 kPa 0 to -760 mmHg graduated at 20 mmHg	
<b>Valve</b>	Pressure non-return valve, ball and seat type	
<b>Australian Standard</b>	AS 2103.3 - 1992	
	<b>Gauge</b>	<b>No Gauge</b>
<b>Height</b>	210 mm	135mm
<b>Width</b>	70 mm	60 mm
<b>Depth</b>	43 mm	43 mm
<b>Weight</b>	250 g	165 g
<b>Duty Cycle</b>	Continuous	
<b>Ambient Temperature</b>	+5°C to 35° C	
<b>Standard Conditions</b>	25°C, Sea Level, 101 kPa	

## Installation and Operation

Carefully examine the High Vacuum Venturi for any visual signs of damage that might have occurred during shipment.

Screw the High Vacuum Venturi to the wall outlet with the yellow ring index handwheel on the back of the unit.

It is recommended that the function and the safety of the Venturi Nozzle be checked at the time of installation and at regular intervals as shown on the Maintenance Schedule on page 9.

Turn on full vacuum via the wall panel control.

Occlude the inlet port at the bottom of the plastic nozzle and check the gauge.

Occlude the Venturi exhaust to check the safety blow back valve. For full testing details see the test descriptions on pages 6 and 7

## Classifications

<b>GMDNS Code</b>	37428
<b>GMDNS Term</b>	Connector, <specify>
<b>Device Class</b>	Class I
<b>Sterilisation</b>	Not Supplied in Sterile State
<b>Operation Mode</b>	Continuous Operation
<b>ARTG Number</b>	141740

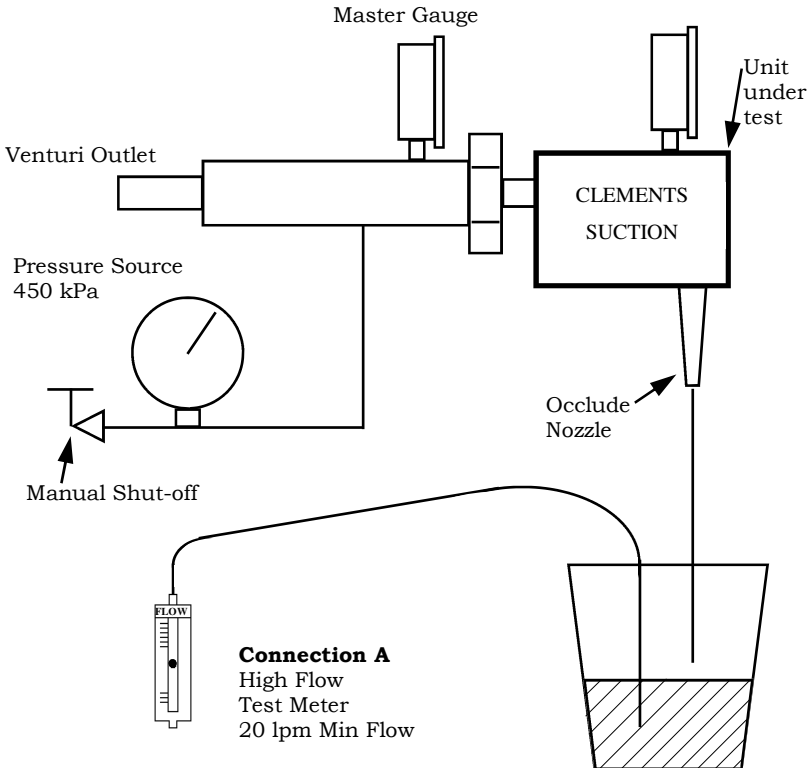
**Vacuum and Flow Test**

To test a Clements Venturi Suction Gauge and flow, use the set-up shown on the diagram above and the procedure shown below.

**Procedure**

- 1 Connect the unit to be tested to a venturi suction outlet.
- 2 Ensure that the primary pressure is set at 450kPa
- 3 Occlude the nozzle at the point shown.
- 4 Check that the reading on the nozzle gauge and the master gauge are the same.
- 5 Connect a high flow test meter as shown for connection A, and ensure that a reading of at least 20 litres per minute is obtained.

## Anti-blowback Test

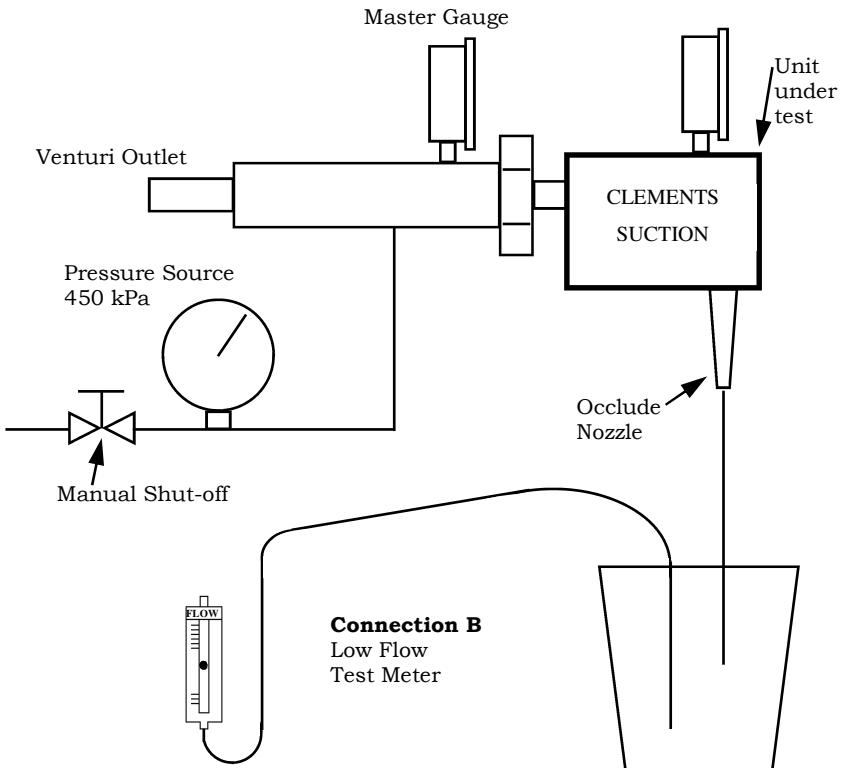

To test a Clements venturi suction nozzle for blowback and correct operation of the non-return valve, use the set-up shown on the diagram above and the procedure shown below.

### Procedure

- 1 Connect the unit to be tested to a venturi suction outlet.
- 2 Ensure that the primary pressure is set at 450kPa
- 3 Connect a low flow test meter as shown for connection B.
- 4 Occlude the venturi outlet and ensure that the meter registers no flow.

## Spare Parts

SUC 89771	Ring Index Connector Kit (Handwheel, nipple and O-Ring)
SUC 80330	High Vacuum Gauge 0 to -100kPa
SUC 80970 001	Plastic Hose Tail with O-Ring (Pack of 20)
SUC 89310 001	Porous Bronze Filter (Pack of 20)
SUC 91005 417	User Manual for High Vacuum High Flow Venturi Nozzle

## Maintenance

The Table below shows a 5 year maintenance schedule based on high to average use.

<b>Year</b>	<b>1st Quarter</b>	<b>2nd Quarter</b>	<b>3rd Quarter</b>	<b>4th Quarter</b>
<b>1</b>	Check flow, vacuum and safety valve.	Check flow, vacuum and safety valve.	Check flow, vacuum and safety valve.	Check flow, vacuum and safety valve.
<b>2</b>	Check flow, vacuum and safety valve.	Check flow, vacuum and safety valve.	Check flow, vacuum and safety valve.	Check flow, vacuum and safety valve. Strip and inspect safety valve parts and replace "O" Ring.
<b>3</b>	Check flow, vacuum and safety valve.	Check flow, vacuum and safety valve.	Check flow, vacuum and safety valve.	Check flow, vacuum and safety valve. And check all "O" Rings and replace if damaged.
<b>4</b>	Check flow, vacuum and safety valve.	Check flow, vacuum and safety valve.	Check flow, vacuum and safety valve.	Check flow, vacuum and safety valve. Strip and inspect safety valve parts and replace "O" Ring.
<b>5</b>	Check flow, vacuum and safety valve.	Check flow, vacuum and safety valve.	Check flow, vacuum and safety valve.	Check flow, vacuum and safety valve.

## **Cleaning and Sterilisation**

### **Sterilisation**

Do not immerse or autoclave unless the gauge, plastic handwheel, nozzle and nylon balls have been removed.

### **Cleaning**

Clean using a pH neutral disinfectant for wiping or immersion cleaning.

Flush after immersion use distilled water and dry before reassembly of unit.

## **Disposal and Recycling**

### **Waste Materials**

The contents of the collection jars, suction tubing, may contain biohazard wastes. Handle using safe handling procedures, which may include the use of rubber gloves and eye protection, and dispose of according to local protocols for biohazard materials.

### **Recycling**

At the end of their service life, the pump and accessories should be dismantled if necessary, and returned to a local materials recycling centre.

## Troubleshooting

<b>Fault</b>	<b>Check</b>	<b>Rectify</b>
No Vacuum / Flow	On / Off Knob Wall outlet blocked Body blocked Filter blocked Gauge faulty	Ensure turned on Refer to engineering dept. Strip and clean Clean or replace
Gauge Faulty	Check against	Replace
Bronze Filter	Damage or corrosion	Autoclave, wash
Safety Valve	'O' Ring	Replace

## Disassembly and Repair

The following description refers to the diagram in page 13.

- 1) Bronze Filter**  
Unscrew nozzle (Item 7). Remove filter (Item 5). To assemble, reverse procedure.
- 2) Gauge (where fitted)**  
Unscrew gauge (Item 4). Apply torque to brass square section only. To assemble, reverse procedure.
- 3) Handwheel**  
Insert Allen key into nipple (Item 2) and unscrew. To assemble, apply sealant, reverse procedure.

<b>Item</b>	<b>Description</b>	<b>Catalogue No</b>
1	'O' Ring	} available
2	Nipple	} in kit
3	Handwheel	} SUC89771
4	Gauge	SUC 80330
5	Filter	SUC 89310 001 (Pack of 20)
6	'O' Ring	} sold together
7	Nozzle	} SUC80970 001 (Pack of 20)

**High Vacuum High Flow Venturi  
Nozzle with Gauge SUC 89346**

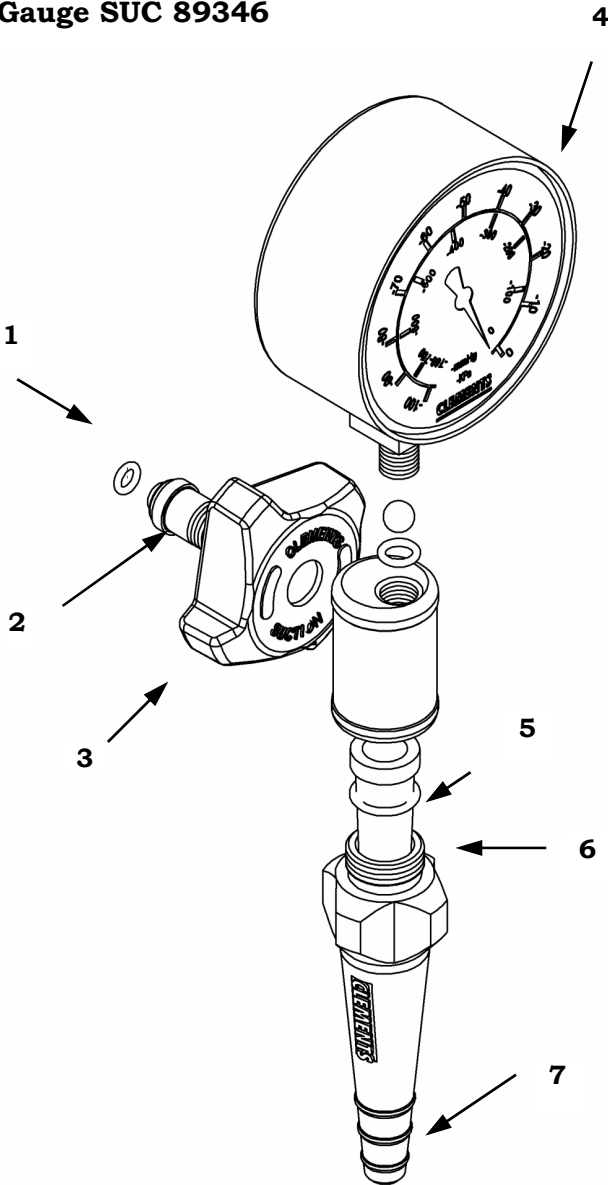

## **Warranty**

BMDi TUTA Healthcare Pty Limited ("BMDi TUTA Healthcare") warrants that this product is free from defects in workmanship and materials for a period of 12 months from the date of shipment by BMDi TUTA Healthcare or its authorised agent to the purchaser. Subject to the conditions of this warranty, if the product fails to operate for any reason within the warranty period and the product is returned to the place of purchase at the purchaser's expense, BMDi TUTA Healthcare will repair or replace the product free of charge.

If a valid warranty claim is made within 30 days from the date of shipment, then BMDi TUTA Healthcare will also reimburse the purchaser for reasonable freight costs in returning the product to the place of purchase.

### **Conditions of Warranty**

1. The product must be returned to the place of purchase with proof of purchase.
2. This warranty is only available to the original purchaser of the product.
3. The product must not have had its serial number removed, defaced or changed, its casing opened, its power supply altered or have been tampered with in any other way.
4. This warranty does not cover :
  - inadequate or incorrect site preparation;
  - improper installation;
  - connection to the wrong voltage;
  - failure of the product due to misuse;
  - the use or operation of the product outside of the physical, electrical or environmental specifications of the product;
  - use in a manner or environment in which the product is not designed to be used;
  - improper adjustment, calibration or operation by the purchaser;
  - the use of accessories including consumables, hardware or software which were not manufactured or approved in writing by BMDi TUTA Healthcare;

- any modifications of the product which were not authorised in writing by BMDi TUTA Healthcare;
  - any contamination or leakages caused or induced by the purchaser; and
  - inadequate or improper maintenance of the product.
5. This warranty does not cover normal wear and tear.
  6. BMDi TUTA Healthcare will not be responsible for damage or loss caused during shipping.
  7. In Australia, apart from any warranties implied by the Trade Practices Act 1974 all other warranties expressed or implied and whether arising by virtue of statute or otherwise are hereby excluded.
  8. Outside Australia, all other warranties expressed or implied and whether arising by virtue of statute or otherwise (including any warranties implied by the Vienna Convention) are hereby excluded.
  9. BMDi TUTA Healthcare' obligations under this warranty are limited to the repair or replacement of the product, within the terms of this warranty and the total liability of BMDi TUTA Healthcare for loss or damage of every kind whether arising pursuant to the terms of the sale of the product or otherwise in connection with the product is limited to the amount paid by the purchaser to BMDi TUTA Healthcare for the product.
  10. Apart from any liability imposed by Part VA of the Trade Practices Act, BMDi TUTA Healthcare accepts no other liability for any loss or damage occasioned (including consequential loss or damages) in any way as a result of the use of the product.
  11. The warranty does not extend to cover damage to the following parts as they are inherently prone to wear :
    - motor brushes
  12. This warranty does not extend to cover corrosion due to any cause nor to any damage to painted or anodised surfaces.
  13. BMDi TUTA Healthcare will give the purchaser the benefit of any manufacturer's warranty in respect of any components in the product which were not manufactured by BMDi TUTA Healthcare, if such a manufacturer's warranty is available.

