CLEMENTS

SUC 89180 SUC 89182 Low Vacuum Thoracic Regulator

proven through performance



User Manual

Manual No. SUC 91005 434
Issue 10

Safety

Thank you for purchasing this Clements Low Vacuum Thoracic Regulator.

For your safety it is imperative that this unit only be operated by authorised personnel in accordance with the instructions as described in this manual. Operated in this way, the Low Vacuum Thoracic Regulator will provide years of service.

Due to continual improvements in product design, the Low Vacuum Thoracic Regulator may vary in detail from the descriptions in this manual. In the event of further questions please contact your local distributor or BMDi TUTA Healthcare direct.

User Manual

Low Vacuum Thoracic Regulator

Manual Number SUC 91005 434 Issue 10

Copyright © 2010 BMDi TUTA Healthcare Pty Ltd

The information in this manual was originated by, and is the exclusive property of BMDi TUTA Healthcare Pty Ltd. It is furnished for customer information only, and is not an authorisation or licence to make this product or to furnish this information to others.



BMDi TUTA Healthcare Pty Ltd

Level 17, 275 Alfred St

North Sydney NSW 2060

Australia

Phone: +61 2 9466 5300

Fax: +61 2 9922 7165

Website: www.bmdituta.com

Contents

Specification	4
Installation and Operation.....	4
Safety Test	6
Maintenance.....	7
Cleaning & Sterilisation.....	8
Accessories and Spare Parts	8
Disassembly and Reassembly	10
Adjusting	12
Parts Assembly	14
Troubleshooting	16
Warranty.....	17
Notes.....	19

Specifications

SUC 89180	Low Vacuum High Flow Thoracic Regulator with Gauge, Safety Jar, Bronze Filter and Ring Index Handwheel Connector
SUC 89182	Low Vacuum High Flow Thoracic Regulator with Gauge, Safety Jar, Bronze Filter and "V" Mounting for Preferred Connector Kit
Vacuum Range	0 to 6.5 \pm 0.5 kPa
Maximum Vacuum	-7kPa
Maximum Flow Rate	At least 15 Litres of Free Air Per Minute (LFAPM)
Regulator Mechanism	Suspended frictionless double diaphragm
Filter	Porous bronze filter, 90 micron
Safety	Pressure safety valve, ball and seat type
Gauge	Capsule type; Dual scale, graduated in kPa and cmH ₂ O
Gauge Range	0 to -8 kPa, graduated at 0.2 kPa 0 to -80 cmH ₂ O, graduated at 2 cmH ₂ O
Environment	Indoor
GMDN Code	37780
ARTG Number	141742

Installation and Operation

Carefully examine the suction regulator for any visual signs of damage that might have occurred during shipment.

Screw the suction regulator to the wall outlet with the index handwheel located at the back of the unit, or slot “V” at back of body into mounting wall bracket.

Turn on full vacuum by rotating the control knob fully clockwise. Occlude the inlet port at the bottom of the safety jar and check the reading on the gauge. The reading should be less than -7 kPa (-70 cm H₂O).

General Usage

To set the regulator to desired setting

- 1) Occlude inlet
- 2) Wind regulator control knob to register higher than required setting
- 3) Allow setting to stabilise
- 4) Slowly wind back regulator knob to required level

Before each use confirm that the maximum vacuum level of -7kPa is not exceeded. Note that a brief overshoot of the gauge, especially when the inlet is abruptly occluded after a longer duration of operating unoccluded, does not mean that the actual vacuum level has similarly overshoot the set point. This is because the dynamic response of the gauge mechanism does not match the dynamic response of the regulator mechanism. The actual vacuum level achieved in such circumstances corresponds to the level shown on the gauge after settling.

Safety Test for Vacuum Regulator with Variable Setting

- 1) Install the regulator to be tested as shown in the diagram.
- 2) Set the vacuum source to -79 kPa and the regulator to -1.6 kPa (-16 cmH₂O).
- 3) Reduce the vacuum source to -53 kPa and read the new occluded vacuum on the regulator gauge.
- 4) Set the regulator to -6.4 kPa (-64 cmH₂O) and adjust the vacuum source from -53 kPa to -79 kPa.
- 5) Read the new occluded vacuum on the regulator gauge.
- 6) Adjust the vacuum source from -79 kPa to -53 kPa and read the new occluded vacuum on the regulator gauge.
- 7) Repeat the above three times.

Each time the source vacuum is changed the regulator gauge should read within 0.4 kPa or 4 cmH₂O of its setting before the change.

Arrangement For Testing Vacuum Regulator with Variable Setting

Variable Vacuum
Source to -92 kPa,
50 LFAPM

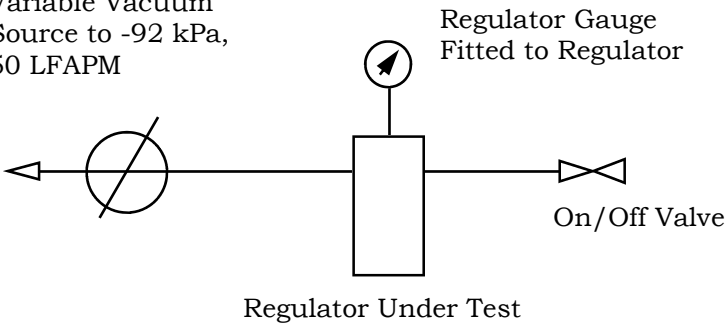

Maintenance

Year	1st Quarter	2nd Quarter	3rd Quarter	4th Quarter
1	Check flow, vacuum, bronze filter and safety valves	Check flow, vacuum, bronze filter and safety valves	Check flow, vacuum, bronze filter and safety valves	Check flow and vacuum, bronze filter and safety valve
2	Check flow, vacuum, bronze filter and safety valves	Check flow, vacuum, bronze filter and safety valves	Check flow, vacuum, bronze filter and safety valves	Check flow and vacuum. Strip and inspect safety valve parts and replace 'O' ring and filter.
3	Check flow, vacuum, bronze filter and safety valves	Check flow, vacuum, bronze filter and safety valves	Check flow, vacuum, bronze filter and safety valves	Check flow and vacuum and safety valve. Check filter and seals, replace if necessary.
4	Check flow, vacuum, bronze filter and safety valves	Check flow, vacuum, bronze filter and safety valves	Check flow, vacuum, bronze filter and safety valves	Check flow and vacuum. Strip and inspect safety valve parts and replace 'O' ring and filter.
5	Check flow, vacuum, bronze filter and safety valves	Check flow, vacuum, bronze filter and safety valves	Check flow, vacuum, bronze filter and safety valves	Check flow and vacuum and safety valve. Check filter and seals, replace if necessary.

CLEMENTS

Cleaning and Sterilisation

Warning

Do not immerse or autoclave the unit unless the gauge, diaphragm assembly and nylon balls have been removed.

Cleaning

Clean using a pH neutral disinfectant for wiping or immersion cleaning. Flush after immersing using distilled water and dry thoroughly before reassembly of the unit.

Sterilisation

The unit may be safely autoclaved once the gauge, diaphragm assembly and nylon balls have been removed.

Spare Parts

MUL 89660 021	Regulator spring
SUC 80254	Very Low Vacuum Gauge for Thoracic Drainage 0 to -8kPa
SUC 89105 434	User Manual for the Low Vacuum Thoracic Regulator SUC89180 / SUC89182
SUC 89150 012	Regulator Assembly Tube
SUC 89210	Safety Trap Jar for Regulators
SUC 89140 029	Knob Tension Spring
SUC 89140 036	Overhaul Kit for Regulators ('O' Ring x4, Large Diaphragm, Small Diaphragm, Valve Seat)
SUC 89250 024	Safety Valve Kit

Accessories

SUC 89140 085	MAK 300 antibacterial canister and lid
SUC 89240 081	MAK 500 canister with lid
SUC 89140 087	Adapter for attaching canister to regulators
SUC 89240 088	MAK 300 jar only
SUC 89240 084	MAK 500 jar only
SUC 89240 090	HEPA bacterial filters for MAK 300 (Pack of 20)
SUC 89101	BS MK IV connector kit
SUC 89102	Puritan Bennett connector kit
SUC 89104	Drager connector kit
SUC 89310 001	Porous Bronze Filter (Pack of 20)
SUC 80297 001	Yellow medical suction tubing (20 metre roll)
SUC 89455 001	Kit, Plastic V bracket to hold suction devices (Pack of 5)

Disassembly and Repair

The Clements Suction Regulator is a precision machined and assembled device that will, under normal operation, provide many years of service. In the event of any malfunction that requires the unit to be dismantled the procedures described below should be followed.

Tools Required

Adjustable Wrench

Allen Keys

Circlip Pliers (internal)

Small Screwdriver

Drill Press (or G Clamp)

Special Tools (Clements SUC 89150 012)

Disassembly

- 1) Remove vacuum gauge.
- 2) Remove safety jar and bronze filter.
- 3) Remove safety jar cap by unscrewing the securing screw. Take care that the small 'O' ring seal is not lost.
- 4) Remove the control knob by loosening the two grub screws.
- 5) Remove the compression spring and the nylon and fibre washers.
- 6) Remove the stop screw from the main body.
- 7) Remove the circlip that retains the diaphragm assembly and the belleville washer.
- 8) Remove the diaphragm assembly.
- 9) Unscrew the diaphragm compressor (left hand thread).
- 10) Remove the circlip from the spring barrel and take out the control screw, and spring.
- 11) Remove the adjusting set screw, washer and spring from inside the control screw.
- 12) Remove the diaphragm and piston assembly.
- 13) Remove the countersunk head screw and disassemble the diaphragm and piston assembly.

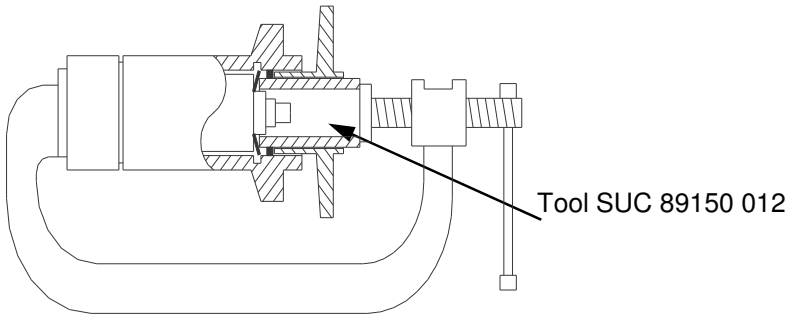

Reassembly

- 1) Reassemble the diaphragm and piston assembly and replace the countersunk head screw.
- 2) Lightly grease the fibre washer and reassemble the adjusting set screw, washer and spring into the control screw.
- 3) Insert the control screw, and spring into the spring barrel and secure with the medium sized circlip.
- 4) Replace the diaphragm compressor (left hand thread) so that it rests lightly against the diaphragm assembly.
- 5) Replace the belleville washer.
- 6) Compress the belleville washer and replace the large circlip. (Clements special tool SUC 89150 012 will be needed for this operation).
- 7) Refit the stop screw into the main body.
- 8) Refit the vacuum gauge using a suitable thread sealant.
- 9) Place the nylon and fibre washers and knob spring into position.
- 10) Lightly grease the 'O' ring and refit the jar cap to the main body with the securing screw.
- 11) Place the bronze filter in its position with a twisting action.
- 12) Insert the safety jar into the jar cap.

Adjusting

Note: When making adjustments, occlude the Safety Jar [7] inlet *gradually* to prevent damaging the gauge by over-running its maximum range. A gauge damaged in this way is not covered by warranty.

Set Control Screw

Initially screw the Safety Valve [15] (with no Loctite applied) right in to prevent it from relieving.

Set the vacuum level to -7kPa by adjusting the Control Screw [14] using the following sequence:

1. Open Safety Jar [7] Inlet
2. Adjust Control Screw [14]
3. *Gradually* occlude the Safety Jar inlet.

Set the Safety Valve

The approach in setting the Safety Valve [15] is to maximize the dynamic performance of the regulator while minimizing the amount of noise generated when it relieves. The optimum dynamic performance is obtained by ensuring that the gauge needle responds at a similar rate in both directions to rapid changes in the Control Knob set point.

Remove the Safety Valve [15] and apply Loctite 510 to the leading threads of the Safety Valve [15] and engage only a few threads into the cap.

Gradually screw in the Safety Valve [15] until it allows the maximum vacuum level of -7kPa to be achieved while still maintaining dynamic performance at minimum noise level.

Set Control Screw

Very gradually unscrew Control Screw [14] until the vacuum level just starts to move away from the -7kPa limit set above.

Carefully push the Control Knob [9] onto the Control Screw [14] without altering its setting. Ensure that the stop pin is hard against the right hand side of the stop screw. Lock it into position with the two grub screws.

Pressing the knob onto the shaft against the spring pressure may result in a maximum setting higher than the -7kPa previously set. If this happens, unscrew the Control Screw [14] further until the required maximum is achieved with the Control Knob [9] is fixed in place.

Set the Zero Deadband

Remove label from Knob [9]. Rotate Knob [9] fully anti-clockwise, then rotate clockwise through 1/8th turn. This will be the zero set position.

Occlude Safety Jar [7] inlet and adjust Adjusting Screw [13] to obtain the setting where the needle moves about the zero point. Confirm that the gauge reads zero over the first 1/8th to 1/4 turn.

Confirm operation of regulator with particular attention to the zero and -7kPa maximum limits.

Turn the Control Knob [9] fully anti-clockwise and affix label so that text is horizontal and pointer is at 6 o'clock.

Check Relief Valve

Set vacuum level to -5kPa. With Safety Jar [7] inlet kept occluded, occlude the small relief hole adjacent to the Relief Valve [17] on the left side of the Jar Cap [12]. Confirm that needle does not move more than 0.2kPa. If needle movement is greater than this, the Relief Valve [17], plastic ball and cap seat must be carefully cleaned (with a non-residue solvent such as methylated spirits) to remove all dirt particles. Replace and re-check.

Final Check

Test the regulator as described in the Installation and Operation section.

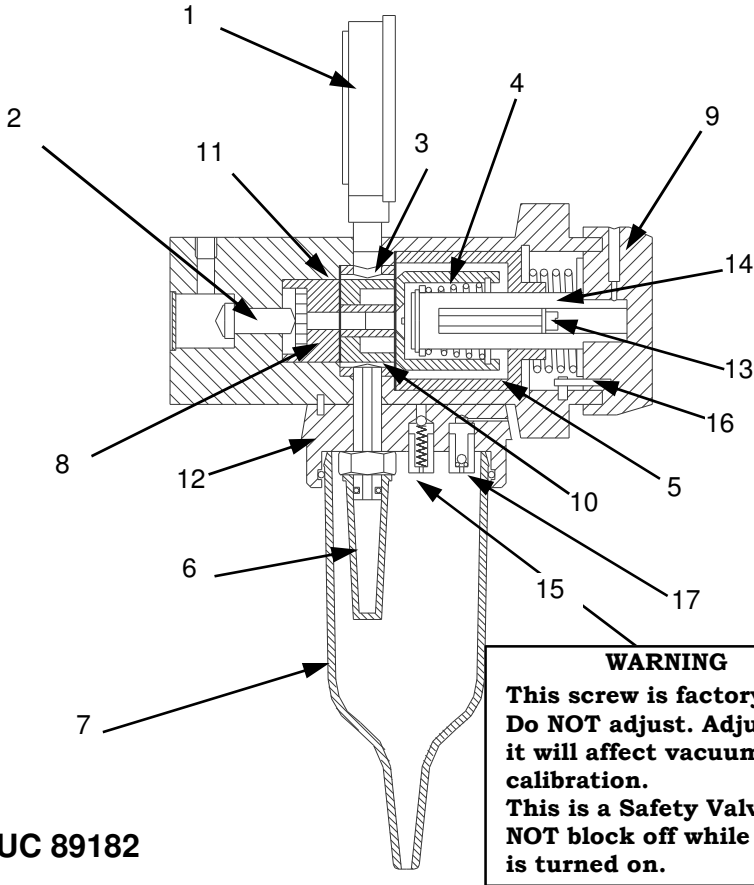

SUC 89182

Item	Description	Item	Description
1	Gauge	9	Control Knob
2	Valve	10	Large Diaphragm
3	Outer Spacer	11	Small Diaphragm
4	Control Spring	12	Jar Cap
5	Diaphragm Compressor	13	Adjusting Screw
6	Bronze Filter	14	Control Screw
7	Safety Jar	15	Safety Valve
8	Piston Assembly	16	Stop Pin
		17	Relief Valve

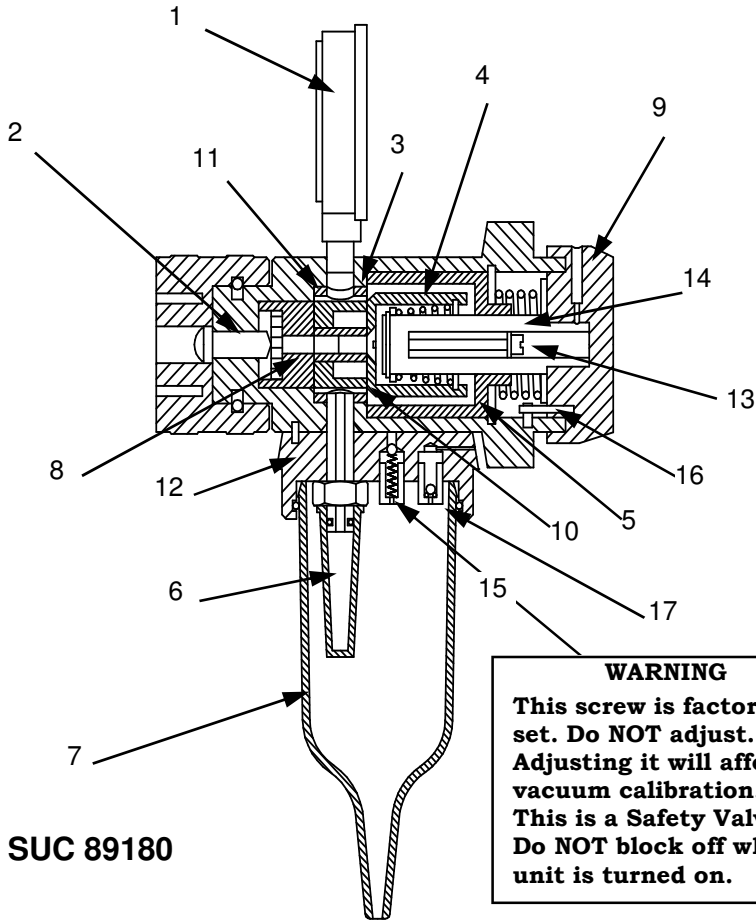

SUC 89180

WARNING
This screw is factory set. Do NOT adjust. Adjusting it will affect vacuum calibration. This is a Safety Valve. Do NOT block off while unit is turned on.

Item	Description	Item	Description
1	Gauge	9	Control Knob
2	Valve	10	Large Diaphragm
3	Outer Spacer	11	Small Diaphragm
4	Control Spring	12	Jar Cap
5	Diaphragm Compressor	13	Adjusting Screw
6	Bronze Filter	14	Control Screw
7	Safety Jar	15	Safety Valve
8	Piston Assembly	16	Stop Pin
		17	Relief Valve

Troubleshooting

Fault	Check	Rectify
No reading on suction gauge	Pipeline supply Safety Jar fitting 'O' Ring Seal Connection to wall Blockage in	Supply source Tighten into body Replace if damaged Tighten handwheel Dismantle and clean
Full scale reading on suction gauge at all settings	Debris on valve seat	Dismantle and clean
Suction gauge reading creeps upwards	Debris on valve seat	Dismantle and clean
Suction gauge reading creeps downwards	Pipeline supply Safety Jar fitting 'O' Ring Seal Regulator Diaphragms	Supply source Tighten into body Replace if damaged Dismantle and check replace if damaged
Slow response to suction setting	Bronze Filter Metering Jet	Clean or replace Replace if worn

Warranty

BMDi TUTA Healthcare Pty Limited (“BMDi TUTA Healthcare”) warrants that this product is free from defects in workmanship and materials for a period of 12 months from the date of shipment by BMDi TUTA Healthcare or its authorised agent to the purchaser. Subject to the conditions of this warranty, if the product fails to operate for any reason within the warranty period and the product is returned to the place of purchase at the purchaser’s expense, BMDi TUTA Healthcare will repair or replace the product free of charge.

If a valid warranty claim is made within 30 days from the date of shipment, then BMDi TUTA Healthcare will also reimburse the purchaser for reasonable freight costs in returning the product to the place of purchase.

Conditions of Warranty

- 1) The product must be returned to the place of purchase with proof of purchase.
- 2) his warranty is only available to the original purchaser of the product.
- 3) The product must not have had its serial number removed, defaced or changed, its casing opened, its power supply altered or have been tampered with in any other way.
- 4) This warranty does not cover :
 - inadequate or incorrect site preparation;
 - improper installation;
 - connection to the wrong voltage;
 - failure of the product due to misuse;
 - the use or operation of the product outside of the physical, electrical or environmental specifications of the product;
 - use in a manner or environment in which the product is not designed to be used;
 - improper adjustment, calibration or operation by the purchaser;
 - the use of accessories including consumables, hardware or software which were not manufactured or approved in writing by BMDi TUTA Healthcare;
 - any modifications of the product which were not authorised in writing by BMDi TUTA Healthcare;
 - any contamination or leakages caused or induced by the purchaser; and
 - inadequate or improper maintenance of the product.
- 5) This warranty does not cover normal wear and tear.
- 6) BMDi TUTA Healthcare will not be responsible for damage or loss caused during shipping.

- 7) In Australia, apart from any warranties implied by the Trade Practices Act 1974 all other warranties expressed or implied and whether arising by virtue of statute or otherwise are hereby excluded.
- 8) Outside Australia, all other warranties expressed or implied and whether arising by virtue of statute or otherwise (including any warranties implied by the Vienna Convention) are hereby excluded.
- 9) BMDi TUTA Healthcare' obligations under this warranty are limited to the repair or replacement of the product, within the terms of this warranty and the total liability of BMDi TUTA Healthcare for loss or damage of every kind whether arising pursuant to the terms of the sale of the product or otherwise in connection with the product is limited to the amount paid by the purchaser to BMDi TUTA Healthcare for the product.
- 10) Apart from any liability imposed by Part VA of the Trade Practices Act, BMDi TUTA Healthcare accepts no other liability for any loss or damage occasioned (including consequential loss or damage) in any way as a result of the use of the product.
- 11) The warranty does not extend to cover damage to the following parts as they are inherently prone to wear :
 - Motor Brushes.
- 12) This warranty does not extend to cover corrosion due to any cause nor to any damage to painted or anodised surfaces.
- 13) BMDi TUTA Healthcare will give the purchaser the benefit of any manufacturer's warranty in respect of any components in the product which were not manufactured by BMDi TUTA Healthcare, if such a manufacturer's warranty is available.

Notes

Notes